



TECHNICAL DATA

Voltage	<i>nominal</i>	70	kV
	<i>maximum for test</i>	80	
Inverse voltage	<i>nominal</i>	85	kV
	<i>maximum for test</i>	93	
Focal spot (IEC 60336:2005)		0.4 (3.5 mA)	mm
		0.8 (7.0 mA)	
Filament characteristics		4 ± 0.1	V
		max 2.8	
Filament life (at 4 V)		120000	s
Nominal anode input power at 0.1 s (DC)		840	W
Grid resistor value		16 ÷ 26 (0.8 focus)	kΩ
		40 ÷ 65 (0.4 focus)	
Maximum dissipation on grid resistor		2	W
Anode material		tungsten	
Target angle		16	°
Anode heat storage capacity		6000	J
Maximum anode cooling rate		90	W
Maximum continuous anode current		8	mA
Inherent filtration		0.5 mm Al	
Maximum diameter		30	mm
Overall length		80 max	mm

GENERAL INFORMATIONS

When mounting tube inserts adopt proper caution, in order to avoid glass bulb breaking and fragments projection. Please use protective gloves and glasses.

Tube insert connected to H.V. supply is a radiation source: be sure to take all necessary safety cautions

- Wash thoroughly with alcohol the external surface of tube insert (care of fire risk). Avoid contact of dirty surfaces with cleaned tube insert.
- Clamp system inside housing or self-contained units must not mechanically stress the tube.
- After installation, check the right working of the tube (no fluctuation of tube current nor crackling)
- Comply with insert thermal parameters, planning and programming the exposure parameters and cooling pauses. Housing or self-contained units must be provided with an adequate thermic protection.
- Voltages indicated in charts are valid for transformer supplied with ground center.
- It is extremely important to observe the connection diagram and the grid resistor value. Any change could modify the dimensions of the focal spot, also varying diagnostic performances or overloading anode target.
- Tube inserts contain environment polluting materials, particularly lead liner tubes. Please apply to qualified operator for waste disposal, according to local regulation requirements.

INCIDENT REPORT ACCORDING TO 93/42/EEC MEDICAL DEVICES DIRECTIVE

In order to comply with CE marking requirements, end users have to report to local Competent Authority all the informations about possible incidents involving the device, regarding any deterioration in its characteristics and performances, as well as any inaccuracies in this documentation, which might lead to or might have led to the death of patient / user or a deterioration in his state of health. This information must be promptly reported also to C.E.I. in order to start manufacturer reporting, as per above mentioned directive.



this mark assures device conformity to EC Directive 93/42 on Medical Devices Safety



CONNECTIONS

DIMENSIONS

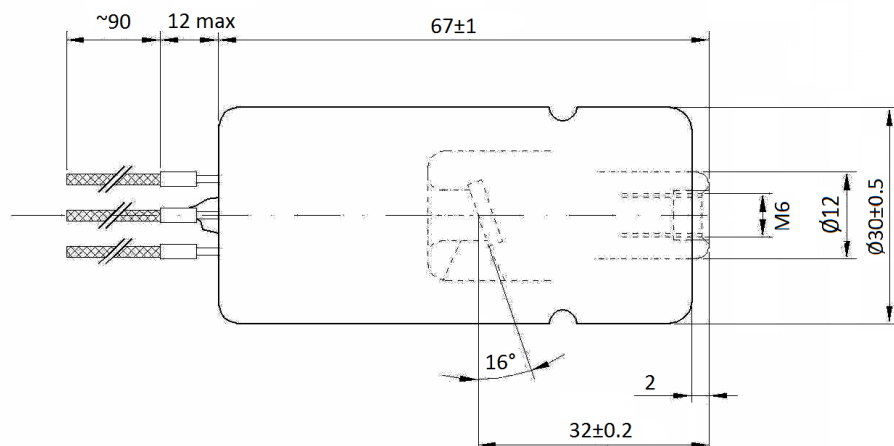

THERMAL CURVES

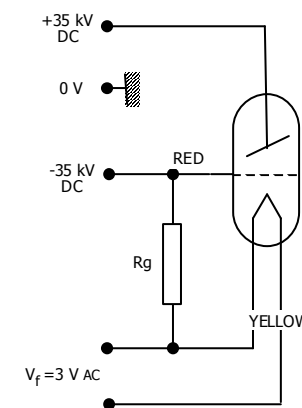
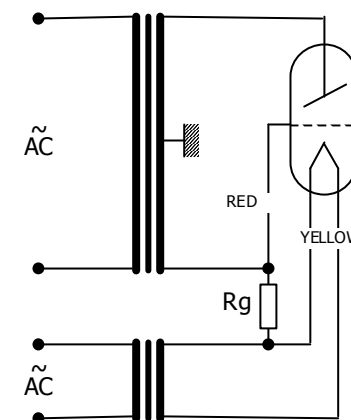
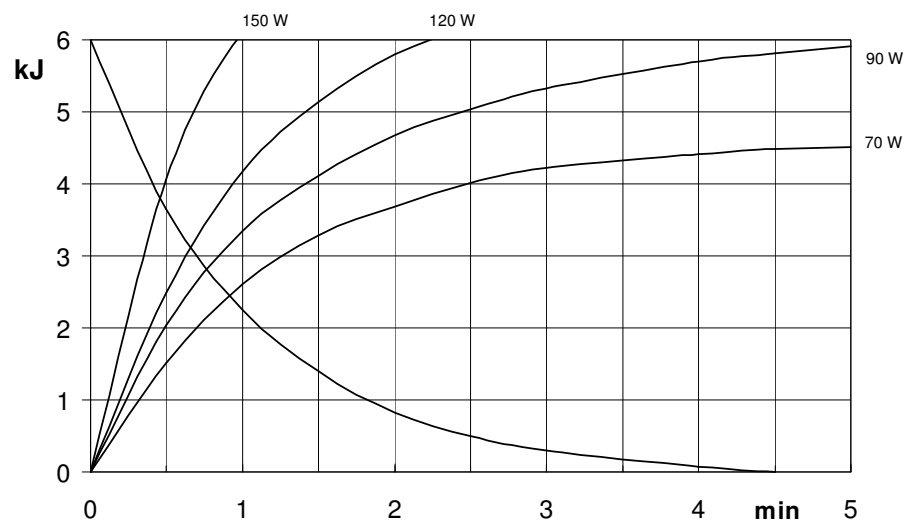



FILAMENT AND EMISSION CHARACTERISTICS

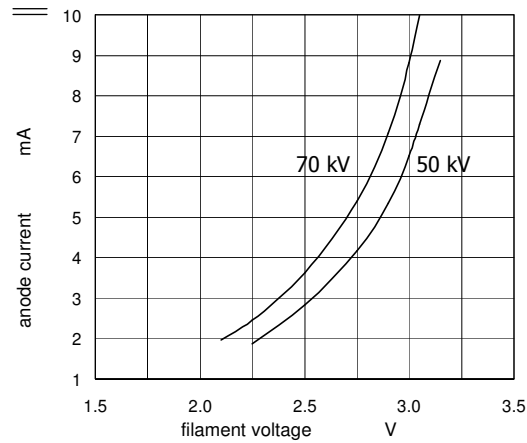
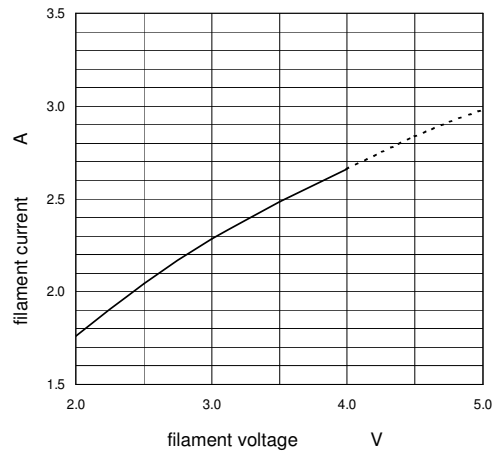

RATING CHARTS

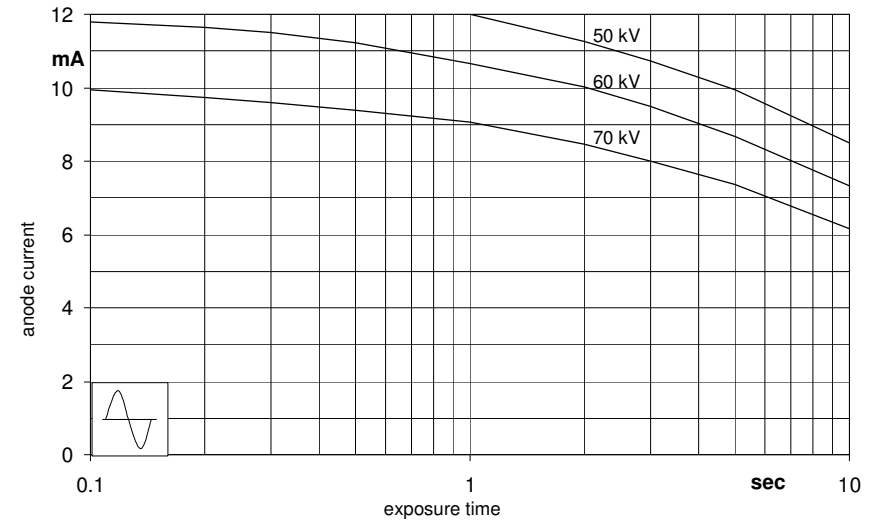

Emission curves (7.0 mA, 0.8 focus)

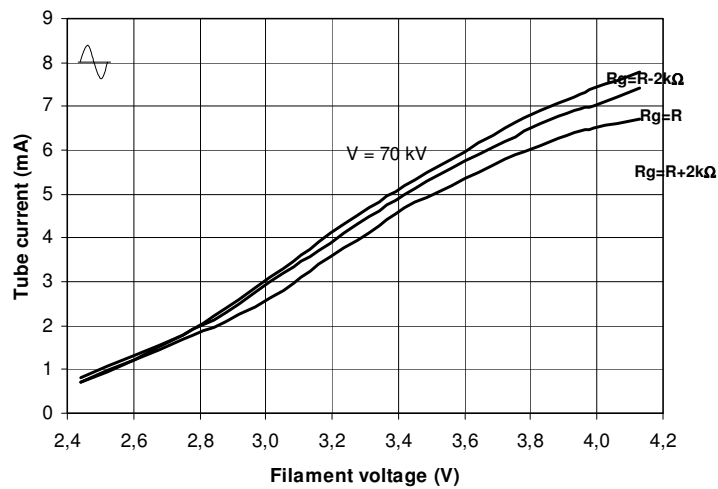

Emission curves (3.5 mA, 0.4 focus)

